



Midimuso CV-12 ORAC

Thanks for buying the Midimuso CV-12 ORAC PCB.

This booklet will help you construct / set up the kit.

For more information on modes, chaining, re-triggering, aftertouch, overflow and polyphony, please refer to the main CV 12 manual on the website (midimuso.co.uk).

Component placement (N.B. Not all the PCB holes are used)

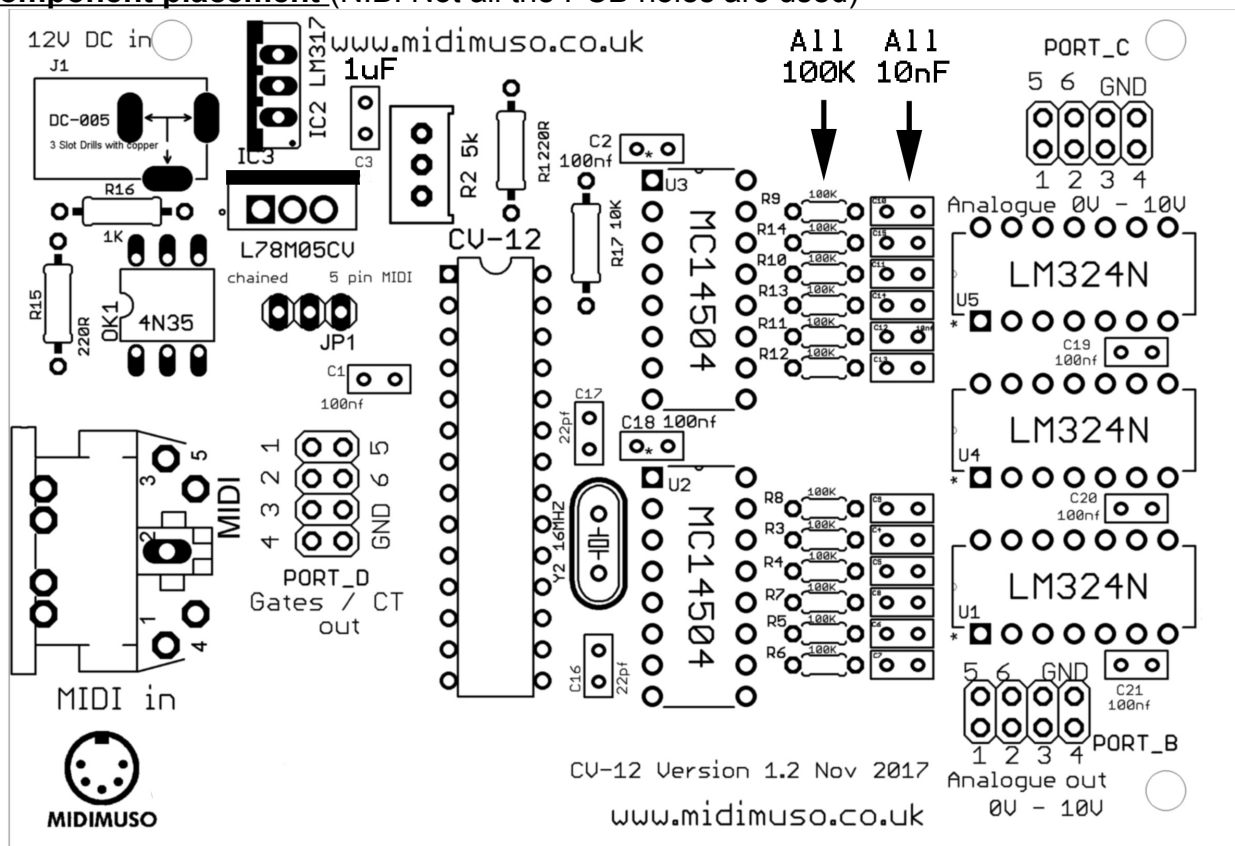

JP1 should be jumpered from centre to pin 3 (adjacent, right) so the IC receives MIDI from the 5 pin DIN connector. C3 (1uF) may be polarised.

Its + terminal should be nearest the top edge of the board.

They are marked as:

$$105 = 1\,000\,000\text{pF} = 1\mu\text{F}$$

$$104 = 100\,000\text{pF} = 0.1\mu\text{F} = 100\text{nF}$$

$$103 = 10\,000\text{pF} = 10\text{nF} = 0.01\mu\text{F}$$

The board can produce 1V / octave or 1.2V / octave or 0.5V / octave just by setting the trimmer correctly.

(You'll need to increase the power supply voltage to 15V for the 1.2V / octave scheme)

On power-up, adjust the trimmer until you see:

Port	Pin	1V / Octave	1.2V / Octave	0.5V / Octave
B	6	6.0 Volts	7.2 Volts	3.0 Volts
B	5	5.0 Volts	6.0 Volts	2.5 Volts
B	4	4.0 Volts	4.8 Volts	2.0 Volts
B	3	3.0 Volts	3.6 Volts	1.5 Volts
B	2	2.0 Volts	2.4 Volts	1.0 Volts
B	1	1.0 Volts	1.2 Volts	0.5 Volts
C	1	5.0 Volts	6.0 Volts	2.5 Volts
C	2	7.0 Volts	8.4 Volts	3.5 Volts
C	3	8.0 Volts	9.6 Volts	4.0 Volts
C	4	9.0 Volts	10.8 Volts	4.5 Volts
C	5	10.0 Volts	12.0 Volts	5.0 Volts

Available Modes

On arrival, the IC is set to MODE 1A. Re-trigger is set to ON.

IC Pin#	PCB port	MODE										1 x poly	4x mono
		0A	0B	1A	1B	2A	2B	4A	4B	6	4PV	4MV	
14	B1	4 foot ctl	A Gate 6	Pitch 1	Pitch 1	Pitch 1	Pitch 1	Pitch 1	Pitch 1	Pitch 1	Pitch 1	Pitch P	Pitch 1
15	B2	95 phaser	A Gate 7	95 phaser	A Gate 5	Pitch 2	Pitch 2	Pitch 2	Pitch 2	Pitch 2	Pitch 2	Pitch P	Pitch 2
16	B3	93 chorus	A Gate 8	93 chorus	A Gate 6	93 chorus	A Gate 4	Pitch 3	Pitch 3	Pitch 3	Pitch 3	Pitch P	Pitch 3
17	B4	94 delay	A Gate 9	94 delay	A Gate 7	94 delay	A Gate 5	Pitch 4	Pitch 4	Pitch 4	Pitch 4	Pitch P	Pitch 4
18	B5	73 attack	A Gate 10	73 attack	A Gate 8	73 attack	A Gate 6	73 attack	A Gate 2	Pitch 5	Velocity P	Velocity 1	
19	B6	72 release	A Gate 11	72 release	A Gate 9	72 release	A Gate 7	72 release	A Gate 3	Pitch 6	Velocity P	Velocity 2	
23	C1	Ptch bend	Ptch bend	Ptch bend	Ptch bend	Ptch bend	Ptch bend	Ptch bend	Ptch bend	Ptch bend	Ptch bend	Ptch bend	Ptch bend
24	C2	1 mod	1 mod	1 mod	1 mod	1 mod	1 mod	1 mod	1 mod	1 mod	1 mod	1 mod	1 mod
25	C3	7 vol	7 vol	7 vol	7 vol	7 vol	7 vol	7 vol	7 vol	7 vol	7 vol	Velocity P	Velocity 3
26	C4	11 expr	11 expr	11 expr	11 expr	11 expr	11 expr	11 expr	11 expr	11 expr	11 expr	Velocity P	Velocity 4
27	C5	71 res/aft	71 res/aft	71 res/aft	71 res/aft	71 res/aft	71 res/aft	71 res/aft	71 res/aft	71 res/aft	71 res/aft	71 res/aft	71 res/aft
28	C6	74 cut off	74 cut off	74 cut off	74 cut off	74 cut off	74 cut off	74 cut off	74 cut off	74 cut off	74 cut off	74 cut off	74 cut off
4	D1	A Gate 1	A Gate 1	P Gate 1	P Gate 1	P Gate 1	P Gate 1	P Gate 1	P Gate 1	P Gate 1	P Gate 1	Gate P	P Gate 1
5	D2	A Gate 2	A Gate 2	A Gate 1	A Gate 1	P Gate 2	P Gate 2	P Gate 2	P Gate 2	P Gate 2	P Gate 2	Gate P	P Gate 2
6	D3	A Gate 3	A Gate 3	A Gate 2	A Gate 2	A Gate 1	A Gate 1	P Gate 3	P Gate 3	P Gate 3	P Gate 3	Gate P	P Gate 3
11	D4	A Gate 4	A Gate 4	A Gate 3	A Gate 3	A Gate 2	A Gate 2	P Gate 4	P Gate 4	P Gate 4	P Gate 4	Gate P	P Gate 4
12	D5	A Gate 5	A Gate 5	A Gate 4	A Gate 4	A Gate 3	A Gate 3	A Gate 1	A Gate 1	P Gate 5	A Gate 1	A Gate 1	A Gate 1
13	D6	CT	CT	CT	CT	CT	CT	CT	CT	P Gate 6	CT	CT	CT
	Prog Change	7	8	0	1	2	3	4	5	6	9	10	
MIDI	Pitch			1	1	1-2	1-2	1-4	1-4	1-6	1	1-4	
Channels	Control	1	1	1	1	1	1	1	1	1	1	1	1
	Aux Gate	16	16	16	16	16	16	16	16	-	16	16	
Overflow	Pitch			2	2	3-4	3-4	5-8	5-8	7-12	1	5-8	
to	Control	2	2	2	2	2	2	2	2	2	2	2	2
Next IC	Aux Gate	16	16	16	16	16	16	16	16	-	16	16	

CT = MIDI Clock

The bottom 7 rows indicate which MIDI channels the outputs respond to, the lower 3 showing overflow behaviour to next chip if chained.

Mode 4PV receives notes on MIDI channel 1 and allocates them to an available output automatically.

CT = MIDI Clock. Pulse length = 1ms. Produces 24 pulses per quarter note e.g. 48 pulses / second @ 120 B.P.M.

Pitch Voltages.

Volts / Octave Moog scheme:			Output		
MIDI key	Value (hex)	Value (decimal)	1V / oct	1.2V / oct	0.5V / oct
A0	15	21	0.00	0.00	0.00
A1	21	33	1.00	1.20	0.50
A2	2D	45	2.00	2.40	1.00
A3	39	57	3.00	3.60	1.50
C4	3C	60	3.25	3.90	1.625
A4	45	69	4.00	4.80	2.00
A5	51	81	5.00	6.00	2.50
A6	5D	93	6.00	7.20	3.00
A7	69	105	7.00	8.40	3.50
A8	75	117	8.00	9.60	4.00

There is disagreement about MIDI key number standards. We used a free MIDI tool called MIDI Ox to display values from the controller keyboard.

<http://www.midiox.com>

Port D – aux gates

e.g, in Mode 1A, pins D2, D3, D4 and D5 are aux gates and are triggered on **MIDI channel 16** by playing notes C3 (60), C#3 (61), D3 (62) and Eb3 (63).

Midi channel 16

PORT - Midi note

D1	60
D2	61
D3	62
D4	63

Changing Modes

Mode change is enabled by sending MIDI program change 99.

Then the desired Mode can be sent as MIDI program change

e.g. Mode 1A = program change "0".

Program #	MODE
0	1A (default)
1	1B
2	2A
3	2B
4	4A
5	4B
6	6
7	0A
8	0B
9	4PV
10	4MV

Example

To change to mode 4B:

send 0xC1 followed by 0x63 (decimal 193, 99)

then send 0xC1 followed by 0x05 (decimal 193, 5)

Hex Decimal

=====

0xC1 193 Program Change

0x63 99 Enables Mode Change (until IC is powered down)

0xC1 193 Program Change

0x05 5 5 = mode 4B

There are MIDI files on the midimuso website to make this easier to do.

You don't have to reset the IC after a Mode change and the IC will remember it is in the new mode even after power off. The mode can be changed again at any time.

Parts List

Resistors:

Qty Value

12 100K R3, R4, R5, R6, R7, R8, R9, R10, R11, R12, R13, R14

1 10K R17

2 220R R1, R15

1 1k R16

1 5k R2 Trimmer / potentiometer

Capacitors:

1 1uf C3

2 22pf C16, C17

6 100nf C1, C2, C18, C19, C20, C21

12 10nf C4, C5, C6, C7, C8, C9, C10, C11, C12, C13, C14, C15

Crystal:

1 16MHZ

Semiconductors:

1 4N35 OK1 Optocoupler

1 L78M05CV IC3

1 LM317 IC2

3 LM324N U1, U4, U5

2 MC14504 U2, U3

1 CV-12 uController

Connectors:

1 DC Jack J1

1 5 pin DIN MIDI socket X1

1 3 way header, single row + jumper

3 8 way header 2 x 4 pin

IC Sockets:

2 16 pin

3 14 pin

1 28 pin

1 6 pin

Specifications:

Power supply voltage: 12 volts DC

Power supply current: 500 mA minimum

Pitch resolution ~ 0.03 semitone

Analogue outputs: 0 – 10 Volts

Gate outputs: 0 – 5 Volts

Contact: email: info@midimuso.co.uk

Continuity guide

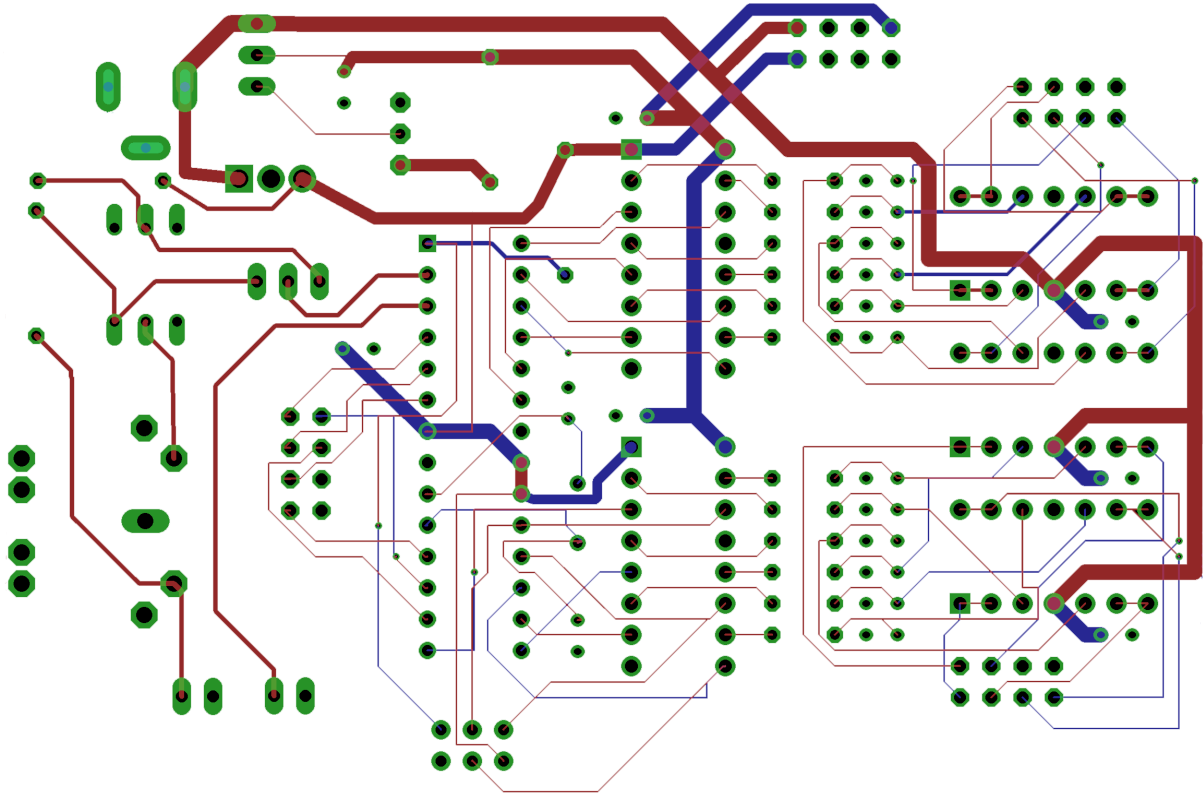

Schematic

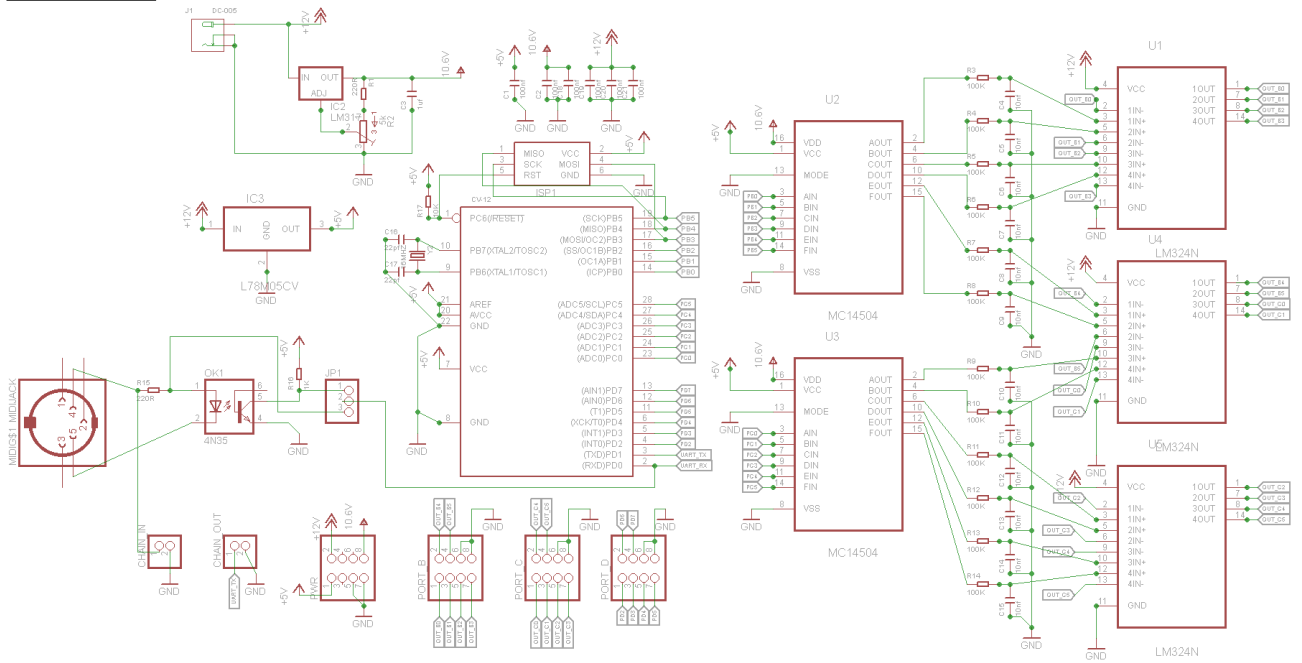

CU-12 version 1.2 Rob Cottam 2017